

COAX[®] cartridge MIDI Si32-2, holding cap, 0107126



- Two-stage COAX[®] cartridge - MIDI - with small mounting dimension for limited spaces.
- Large vacuum flow in relation to energy consumption.
- Suitable for high-volume evacuation when handling porous materials or if surface leakage is present.
- Efficient generator of blow-air. Recommended for low overpressures (0 - 0.05 MPa).

General

Material	PA, SS, Al, Nitrile (NBR)
Temperature	-10 – 80 °C
Weight	27 – 57 g

Performance

Feed pressure, max.	0.7 MPa
---------------------	---------

Vacuum flow

Feed pressure MPa	Air consumption NI/s	Vacuum flow (NI/s) at different vacuum levels (-kPa)									Max vacuum -kPa
		0	10	20	30	40	50	60	70	70	
0.4	1.25	3.1	2.6	1.9	1.2	0.8	0.4	0.1	—	60	
0.5	1.5	3.2	2.9	2.2	1.4	0.85	0.62	0.35	0.18	70	
0.6	1.75	3.3	3	2.6	1.7	0.9	0.6	0.5	0.35	75	

Evacuation time

Feed pressure MPa	Air consumption NI/s	Evacuation time (s/l) to reach different vacuum levels (-kPa)								Max vacuum -kPa
		10	20	30	40	50	60	70	70	
0.4	1.25	0.04	0.08	0.14	0.24	0.42	1	—	60	
0.5	1.5	0.03	0.07	0.11	0.21	0.35	0.6	1	70	
0.6	1.75	0.03	0.07	0.1	0.18	0.33	0.53	0.8	75	

Blow flow

Feed pressure MPa	Air consumption NI/s	Blow flow (NI/s) at different pressure levels (kPa)										Max pressure kPa
		0	10	20	30	40	50	60	70	80	80	
0.6	1.75	5.05	4.83	4.25	3.61	3.3	2.89	2.65	2.35	1.97	80	

Dimensional drawings

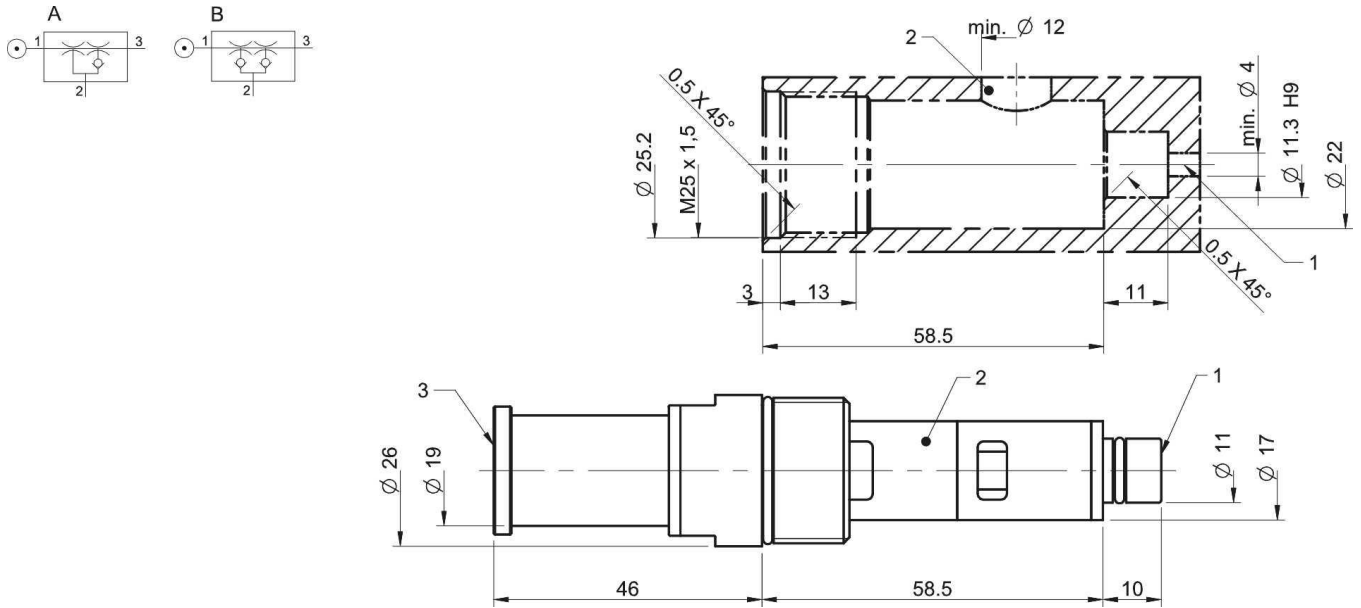

Values specified in the data sheet are tested at:

Room temperature	(20°C [68°F] ± 3°C [5.5°F])
Standard atmosphere	(101.3 [29.9 inHg] ± 1.0 kPa [0.3 inHg])
Relative humidity	0-100%
Compressed air quality	DIN ISO 8573-1 class 4

Spare parts

	Item no.
Spare part kit Midi COAX	0109531
Spare part kit Midi COAX Viton	0124897
Cartridge holder Midi-2 cpl.	0107130

Accessories

	Item no.
Silencer COAX® MIDI	0111976