

Vacuum pump MINI X40L, conn. K, NBR sealings, 0100423



- Extra vacuum level to 93 -kPa
- Small size and low weight
- Use in tightly sealed or non-porous applications

General

Material	ABS, NBR (FKM), PA, POM, SS, Al
Noise level	60 – 70 dBA
Temperature	-20 – 80 °C
Weight, max.	420 g

Vacuum flow

Feed pressure MPa	Air consumption NI/s	Vacuum flow (NI/s) at different vacuum levels (-kPa)											Max vacuum -kPa
		0	10	20	30	40	50	60	70	80	90		
0.4	3.1	3.2	1.5	1	0.9	0.7	0.6	0.5	0.4	0.17	0.038	93	

Evacuation time

Feed pressure MPa	Air consumption NI/s	Evacuation time (s/l) to reach different vacuum levels (-kPa)										Max vacuum -kPa
		10	20	30	40	50	60	70	80	90		
0.4	3.1	0.038	0.12	0.22	0.33	0.48	0.68	1.2	2.2	3.2	93	

Dimensional drawings

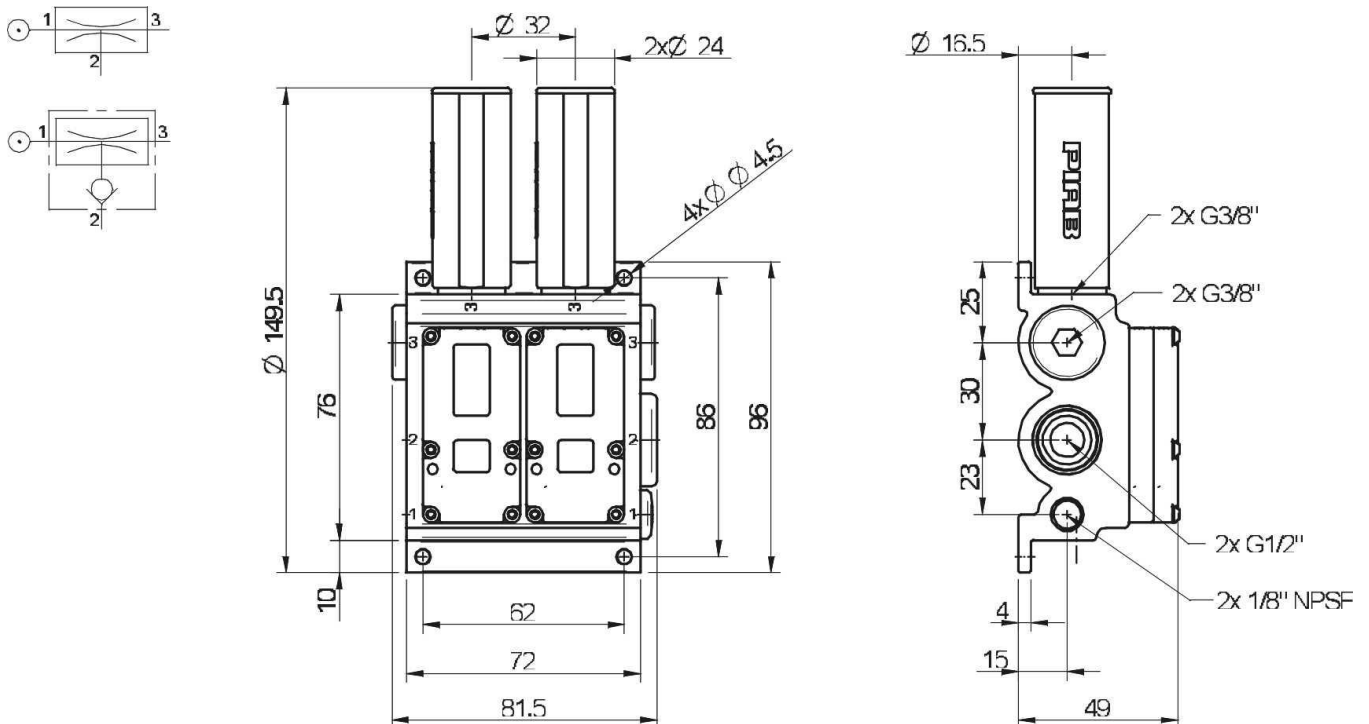

Values specified in the data sheet are tested at:

Room temperature	(20°C [68°F] ± 3°C [5.5°F])
Standard atmosphere	(101.3 [29.9 inHg] ± 1.0 kPa [0.3 inHg])
Relative humidity	0-100%
Compressed air quality	DIN ISO 8573-1 class 4

Spare parts

	Item no.
Sealing kit MINI 30-60, NBR	0100491