

LM Position Switches

- Metal housing, one conduit entry
- Protection degree IP67 according to EN 60529
- 17 contact blocks available
- 43 actuators available
- M12 assembled connector versions
- Silver contacts gold plated versions
- Other versions available (see LR, LX, LZ datasheets)



Approvals



General data

Ambient temperature:	-25°C ... +80°C
Max. actuation frequency:	3600 operating cycles/hour
Mechanical endurance:	20 million operating cycles ¹
Mounting position:	any
Safety parameters:	
B _{10d} :	40,000,00 for NC contacts
Mechanical interlock, not coded:	type 1 according to EN ISO 14119

(1) One operation cycle means two movements, one to close and one to open contacts, as defined in EN 60947-5-1.

Cable cross section (flexible copper strands)

Contact blocks C20, C21, C22, C33, C34:	min. 1 x 0.34 mm ²	(1 x AWG 22)
	max. 2 x 1.5 mm ²	(2 x AWG 16)
Contact block C5, C6, C7, C9, C10, C11, C12, C13, C14, C15, C16, C18:	min. 1 x 0.5 mm ²	(1 x AWG 20)
	max. 2 x 2.5 mm ²	(2 x AWG 14)
Contact block C2:	min. 1 x 0.5 mm ²	(1 x AWG 20)
	max. 2 x 1.5 mm ²	(2 x AWG 16)

In conformity with standards:

IEC 60947-5-1, EN 60947-5-1, EN 60947-1, EN 50047, IEC 60204-1, EN 60204-1, EN ISO 14119, EN ISO 12100, IEC 60529, EN 60529, UL 508, CSA 22.2 No.14 .

Approvals:

IEC 60947-5-1, UL 508, CSA 22.2 No.14, GB14048.5-2001.

In conformity with the requirements of:

Low Voltage Directive 2006/95/EC, Machinery Directive 2006/42/EC and EMC Directive 2004/108/EC.

Positive contact opening in conformity with standards:

IEC 60947-5-1, EN 60947-5-1.

Installation for safety applications:

Use only switches marked with the symbol ⊕ aside the product code. Always connect the safety circuit to the **NC contacts** (normally closed contacts: C11-C12, C21-C22 or C31-C32) as stated in **standard EN 60947-5-1, encl. K, par. 2**. Actuate the switch **at least up to the positive opening travel** shown in the travel diagrams. Operate the switch **at least with the positive opening force**, indicated between brackets below each article, aside the minimum force value.

Electrical data

Utilization category

without connector	Thermal current (I _{th}):	10 A	Alternating current: AC15 (50 ÷ 60 Hz)			
	Rated insulation voltage (U _i):	500 Vac 600 Vdc 400 Vac 500 Vdc (contact blocks 2, 11, 12, 20, 21, 22, 33, 34)	U _e (V)	250	400	500
	Rated impulse withstand voltage (U _{imp}):	6 kV 4 kV (contact blocks 20, 21, 22, 33, 34)	I _e (A)	6	4	1
	Conditional short circuit current: Protection against short circuits: Pollution degree:	1000 A according to EN 60947-5-1 type aM fuse 10 A 500 V 3	Direct current: DC13	U _e (V)	24	125
with M12 connector 5 poles	Thermal current (I _{th}):	4 A	Alternating current: AC15 (50 ÷ 60 Hz)			
	Rated insulation voltage (U _i):	250 Vac 300 Vdc	U _e (V)	24	120	250
	Protection against short circuits:	type gG fuse 4 A 500 V	I _e (A)	4	4	4
	Pollution degree:	3	Direct current: DC13	U _e (V)	24	125
with M12 connector 8 poles	Thermal current (I _{th}):	2 A	Alternating current: AC15 (50 ÷ 60 Hz)			
	Rated insulation voltage (U _i):	30 Vac 36 Vdc	U _e (V)	24		
	Protection against short circuits:	type gG fuse 2 A 500 V	I _e (A)	2		
	Pollution degree:	3	Direct current: DC13	U _e (V)	24	
			I _e (A)	2		

Specifications

Rated insulation voltage (Ui): 500 Vac
400 Vac (for contact blocks C2, C11, C12, C20, C21, C22, C33, C34)

Conventional free air thermal current (Ith): 10 A

Protection against short circuits: type aM fuse 10 A 500 V

Rated impulse withstand voltage (U_{imp}): 6 kV
4 kV (for contact blocks C20, C21, C22, C33, C34)

Protection degree of the housing: IP67

MV terminals (screw terminals)

Pollution degree 3

Utilization category: AC15

Operating voltage (Ue): 400 Vac (50 Hz)

Operating current (Ie): 3 A

Forms of the contact element: Za, Zb, Za+Za, Y+Y, X+X, Y+Y+X, Y+Y+Y, Y+X+X

Positive opening of contacts on contact blocks C5, C6, C7, C9, C11, C13, C14, C16, C18, C20, C21, C22, C33, C34

In conformity with standards: EN 60947-1, EN 60947-5-1 + A1:2009, fundamental requirements of the Low Voltage Directive 2006/95/EC.

Please contact our technical service for the list of approved products.

UL Approval

Utilization categories Q300 (69 VA, 125 ... 250 Vdc)
A600 (720 VA, 120 ... 600 Vac)

Data of housing type 1, 4X "indoor use only", 12, 13

For all contact blocks except C2 and C3 use 60 or 75°C copper (Cu) conductor, rigid or flexible, wire size AWG 12/14. Terminal tightening torque of 7.1 lb in (0.8 Nm).

For contact blocks C2 and C3 use 60 or 75 °C copper (Cu) conductor, rigid or flexible, wire size AWG 14. Terminal tightening torque of 12 lb in (1.4 Nm).

In conformity with standard: UL 508, CSA 22.2 No.14

Please contact our technical service for the list of approved products.

Connection diagram for M12 connectors

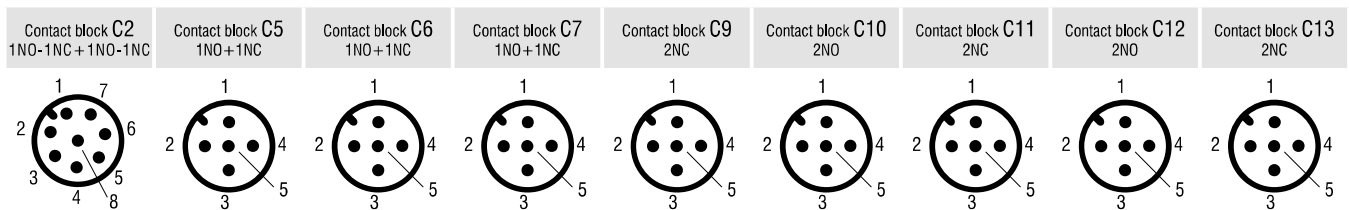

M12 connector, 8 poles M12 connector, 5 poles M12 connector, 5 poles M12 connector, 5 poles M12 connector, 5 poles M12 connector, 5 poles M12 connector, 5 poles M12 connector, 5 poles M12 connector, 5 poles

Contacts	Pin no.	Contacts	Pin no.	Contacts	Pin no.	Contacts	Pin no.	Contacts	Pin no.	Contacts	Pin no.	Contacts	Pin no.	Contacts	Pin no.
NO	3-4	NC	1-2	NC	1-2	NC	1-2	NC	1-2	NO	1-2	NC	1-2	NO	1-2
NC	5-6	NO	3-4	NO	3-4	NO	3-4	NC	3-4	NO	3-4	NC	3-4	NO	3-4
NC	7-8	ground	5	ground	5	ground	5	ground	5	ground	5	ground	5	ground	5
NO	1-2														

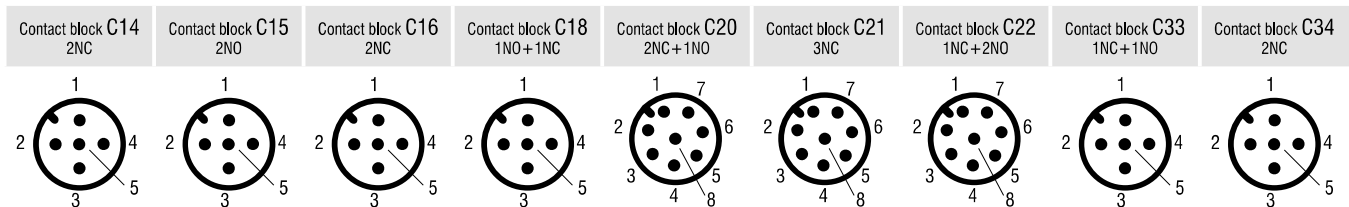

M12 connector, 5 poles M12 connector, 5 poles M12 connector, 5 poles M12 connector, 5 poles M12 connector, 8 poles M12 connector, 8 poles M12 connector, 8 poles M12 connector, 5 poles M12 connector, 5 poles

Contacts	Pin no.	Contacts	Pin no.	Contacts	Pin no.	Contacts	Pin no.	Contacts	Pin no.	Contacts	Pin no.	Contacts	Pin no.	Contacts	Pin no.
NC (1°)	1-2	NO (1°)	1-2	NC, lever at the right	1-2	NC	1-2	NC	3-4	NC	3-4	NC	3-4	NC	1-2
NC (2°)	3-4	NO (2°)	3-4	NC, lever to the left	3-4	NO	3-4	NC	5-6	NC	5-6	NO	5-6	NO	3-4
ground	5	ground	5	ground	5	ground	5	NO	7-8	NC	7-8	NO	7-8	ground	5
						ground	1	ground	1	ground	1	ground	1		

Contact block CE1
PNP

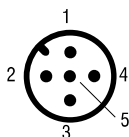

M12 connector, 5 poles

Contacts	Pin no.
+	1
-	3
NC	2
NO	4
ground	5

Selection diagram

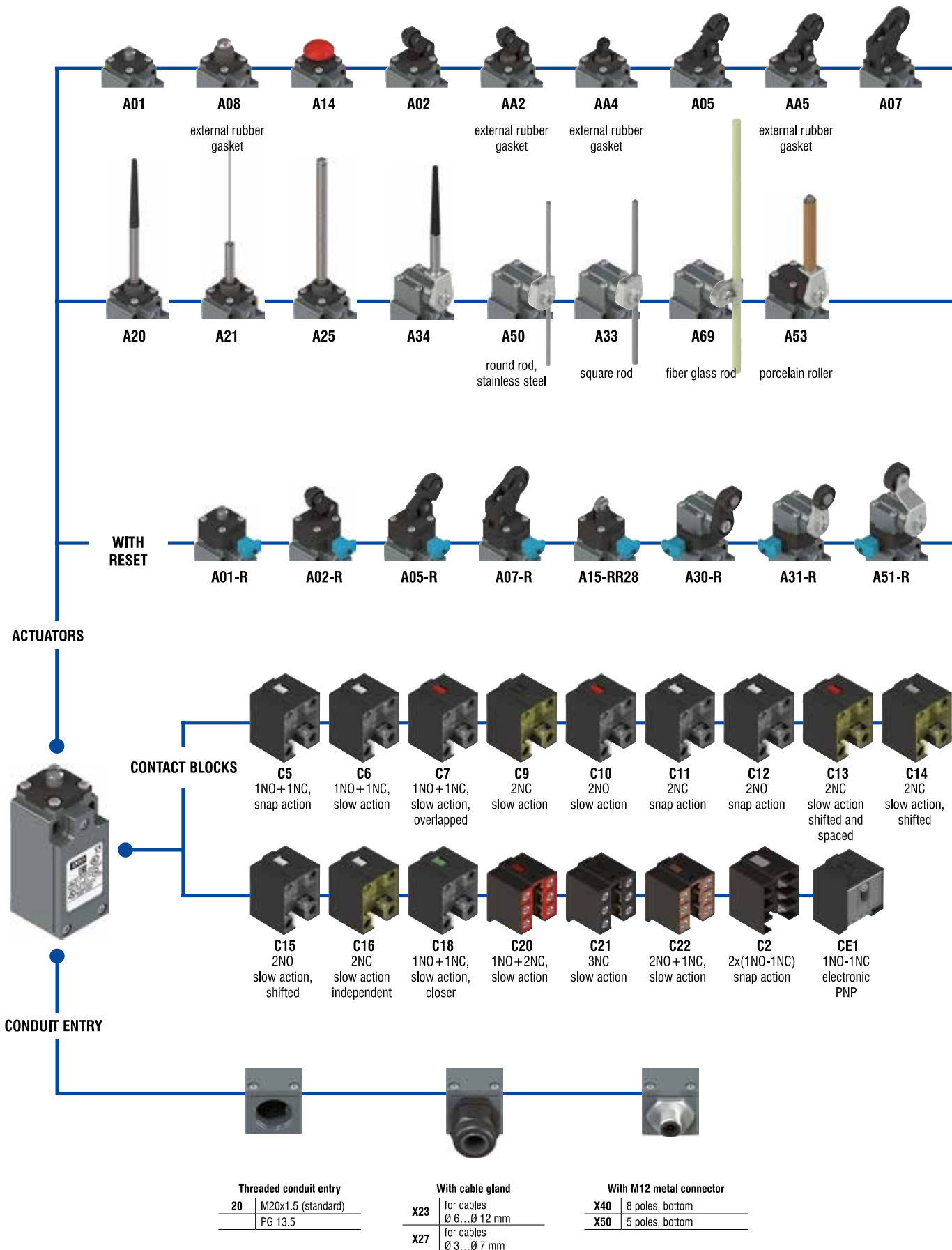

● product options
→ accessory sold separately



AA7 external rubber gasket
A15-R28 Roller Ø 12 mm, stainless steel
A16 roller Ø 20 mm
A12
A13 roller Ø 12 mm, stainless steel
A76 rope switch for signalling



A30 **A31** **A51** **A52** **A54** **A55** adjustable lever
A56 adjustable safety lever
A57 **A38** without actuator

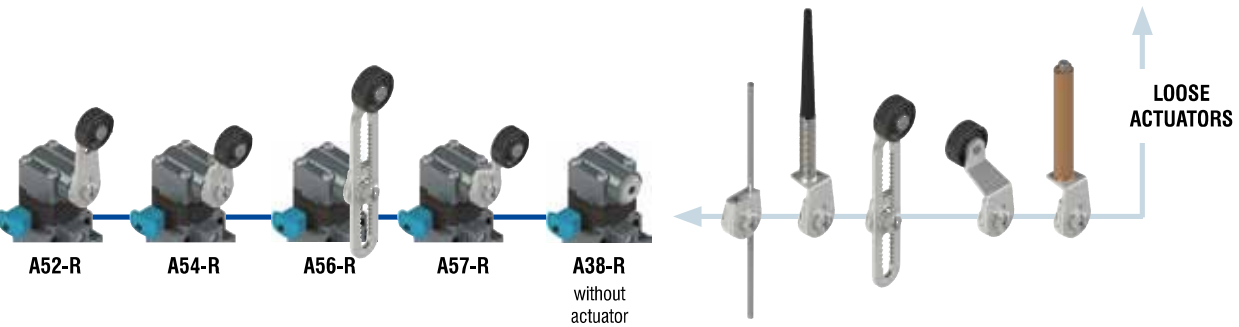

A52-R **A54-R** **A56-R** **A57-R** **A38-R** without actuator

Options & Ordering Codes

Attention! The feasibility of a code number does not mean the effective availability of a product. Please contact our sales office.

LM	C5	A02	-	3	R	G	20	X50	H6
Housing								Operating Temperature	
polymer, one conduit entry		LM						Standard -25°C to +80°C	
Contact Blocks								H6 Low -40°C to +80°C *	
1NO+1NC, snap action		C5						Preinstalled Cable Gland or Connectors	
1NO+1NC, slow action		C6						no cable gland or connector (standard)	
1NO+1NC, slow action, overlapped		C7						X21 assembled cable gland	
.....		...						X50 5 poles M12 assembled metal connector	
Other contact blocks available upon request								Threaded Conduit Entry	
Actuators								PG 13.5 (standard)	
short plunger		A01						20 M20 x 1.5	
roller lever		A02						Contacts Type	
offset roller lever		A05						silver contacts (standard)	
Other actuators available upon request								G silver contacts gold plated 1µm	
Suffix								Reset Hooking	
no suffix (standard)								without reset (standard)	
with stainless steel roller: - Ø 14mm for actuators A2, A02, A5, A05 - Ø 20mm for actuators A30, A31, A51, A52, A54, A55, A56, A57		1						R simultaneous reset	
with Ø 35mm polymer roller		2						RI simultaneous reset with increased force	
with Ø 50mm rubber roller		3							
with Ø 50mm overhanging rubber roller		4							

*not possible with all options

Contact type:

- R** = snap action
- L** = slow action
- LO** = slow action overlapped
- LS** = slow action shifted
- LV** = slow action shifted and spaced
- LI** = slow action independent
- LA** = slow action closer
- ⏏** = electronic PNP

Contact blocks

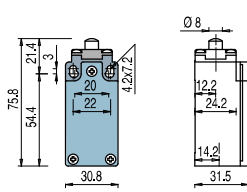

With stainless steel roller on request

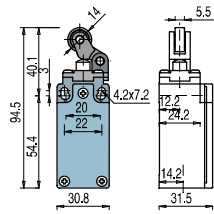

With external rubber gasket

With stainless steel roller on request

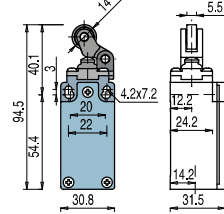

With external rubber gasket

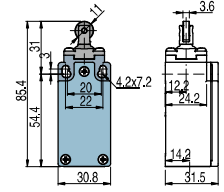

C5	R	LMC5A01	⊕ 1NO+1NC	LMC5A02	⊕ 1NO+1NC	LMC5AA2	⊕ 1NO+1NC	LMC5AA4	⊕ 1NO+1NC
C6	L	LMC6A01	⊕ 1NO+1NC	LMC6A02	⊕ 1NO+1NC	LMC6AA2	⊕ 1NO+1NC	LMC6AA4	⊕ 1NO+1NC
C7	LO	LMC7A01	⊕ 1NO+1NC	LMC7A02	⊕ 1NO+1NC	LMC7AA2	⊕ 1NO+1NC	LMC7AA4	⊕ 1NO+1NC
C9	L	LMC9A01	⊕ 2NC	LMC9A02	⊕ 2NC	LMC9AA2	⊕ 2NC	LMC9AA4	⊕ 2NC
C10	L	LMC10A01	2NO	LMC10A02	2NO	LMC10AA2	2NO	LMC10AA4	2NO
C11	R	LMC11A01	⊕ 2NC	LMC11A02	⊕ 2NC	LMC11AA2	⊕ 2NC	LMC11AA4	⊕ 2NC
C12	R	LMC12A01	2NO	LMC12A02	2NO	LMC12AA2	2NO	LMC12AA4	2NO
C13	LV	LMC13A01	⊕ 2NC	LMC13A02	⊕ 2NC	LMC13AA2	⊕ 2NC	LMC13AA4	⊕ 2NC
C14	LS	LMC14A01	⊕ 2NC	LMC14A02	⊕ 2NC	LMC14AA2	⊕ 2NC	LMC14AA4	⊕ 2NC
C15	LS	LMC15A01	2NO	LMC15A02	2NO	LMC15AA2	2NO	LMC15AA4	2NO
C18	LA	LMC18A01	⊕ 1NO+1NC	LMC18A02	⊕ 1NO+1NC	LMC18AA2	⊕ 1NO+1NC	LMC18AA4	⊕ 1NO+1NC
C20	L	LMC20A01	⊕ 1NO+2NC	LMC20A02	⊕ 1NO+2NC	LMC20AA2	⊕ 1NO+2NC	LMC20AA4	⊕ 1NO+2NC
C21	L	LMC21A01	⊕ 3NC	LMC21A02	⊕ 3NC	LMC21AA2	⊕ 3NC	LMC21AA4	⊕ 3NC
C22	L	LMC22A01	⊕ 2NO+1NC	LMC22A02	⊕ 2NO+1NC	LMC22AA2	⊕ 2NO+1NC	LMC22AA4	⊕ 2NO+1NC
C2	R	LMC2A01	2x(1NO-1NC)	LMC2A02	2x(1NO-1NC)	LMC2AA2	2x(1NO-1NC)	LMC2AA4	2x(1NO-1NC)
CE1	⏏	LMCE1A01	1NO-1NC	LMCE1A02	1NO-1NC	LMCE1AA2	1NO-1NC	LMCE1AA4	1NO-1NC
Max. speed		Type 4		Type 3		Type 3		Type 5	
Min. force		8 N (25 N ⊕)		6 N (25 N ⊕)		4.3 N (25 N ⊕)		4.3 N (25 N ⊕)	
Travel diagrams		Group 1		Group 2		Group 2		Group 1	

With stainless steel roller on request

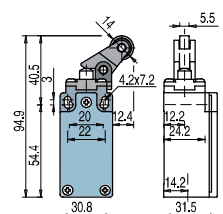

With external rubber gasket

With stainless steel roller on request

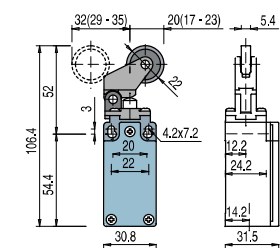
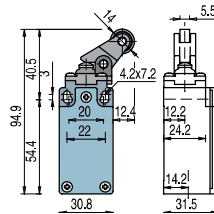

With external rubber gasket

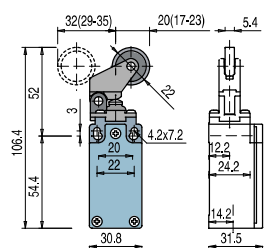

Contact blocks

C5	R	LMC5A05	⊕ 1NO+1NC	LMC5AA5	⊕ 1NO+1NC	LMC5A07	⊕ 1NO+1NC	LMC5AA7	⊕ 1NO+1NC
C6	L	LMC6A05	⊕ 1NO+1NC	LMC6AA5	⊕ 1NO+1NC	LMC6A07	⊕ 1NO+1NC	LMC6AA7	⊕ 1NO+1NC
C7	LO	LMC7A05	⊕ 1NO+1NC	LMC7AA5	⊕ 1NO+1NC	LMC7A07	⊕ 1NO+1NC	LMC7AA7	⊕ 1NO+1NC
C9	L	LMC9A05	⊕ 2NC	LMC9AA5	⊕ 2NC	LMC9A07	⊕ 2NC	LMC9AA7	⊕ 2NC
C10	L	LMC10A05	2NO	LMC10AA5	2NO	LMC10A07	2NO	LMC10AA7	2NO
C11	R	LMC11A05	⊕ 2NC	LMC11AA5	⊕ 2NC	LMC11A07	⊕ 2NC	LMC11AA7	⊕ 2NC
C12	R	LMC12A05	2NO	LMC12AA5	2NO	LMC12A07	2NO	LMC12AA7	2NO
C13	LV	LMC13A05	⊕ 2NC	LMC13AA5	⊕ 2NC	LMC13A07	⊕ 2NC	LMC13AA7	⊕ 2NC
C14	LS	LMC14A05	⊕ 2NC	LMC14AA5	⊕ 2NC	LMC14A07	⊕ 2NC	LMC14AA7	⊕ 2NC
C15	LS	LMC15A05	2NO	LMC15AA5	2NO	LMC15A07	2NO	LMC15AA7	2NO
C18	LA	LMC18A05	⊕ 1NO+1NC	LMC18AA5	⊕ 1NO+1NC	LMC18A07	⊕ 1NO+1NC	LMC18AA7	⊕ 1NO+1NC
C20	L	LMC20A05	⊕ 1NO+2NC	LMC20AA5	⊕ 1NO+2NC	LMC20A07	⊕ 1NO+2NC	LMC20AA7	⊕ 1NO+2NC
C21	L	LMC21A05	⊕ 3NC	LMC21AA5	⊕ 3NC	LMC21A07	⊕ 3NC	LMC21AA7	⊕ 3NC
C22	L	LMC22A05	⊕ 2NO+1NC	LMC22AA5	⊕ 2NO+1NC	LMC22A07	⊕ 2NO+1NC	LMC22AA7	⊕ 2NO+1NC
C2	R	LMC2A05	2x(1NO-1NC)	LMC2AA5	2x(1NO-1NC)	LMC2A07	2x(1NO-1NC)	LMC2AA7	2x(1NO-1NC)
CE1	⏏	LMCE1A05	1NO-1NC	LMCE1AA5	1NO-1NC	LMCE1A07	1NO-1NC	LMCE1AA7	1NO-1NC
Max. speed		Type 3		Type 3		Type 3		Type 3	
Min. force		6 N (25 N ⊕)		4.3 N (25 N ⊕)		4 N (25 N ⊕)		3 N (25 N ⊕)	
Travel diagrams		Group 2		Group 2		Group 3		Group 3	

All measures in the drawings are in mm

Contact type:

- R** = snap action
- L** = slow action
- LO** = slow action overlapped
- LS** = slow action shifted
- LV** = slow action shifted and spaced
- LI** = slow action independent
- LA** = slow action closer
- ⏏** = electronic PNP

Contact blocks

With external rubber gasket

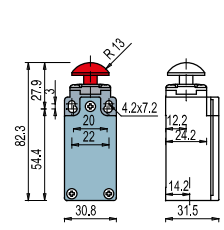
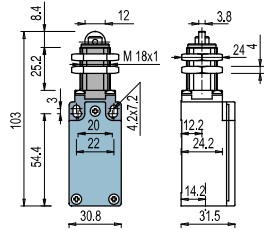
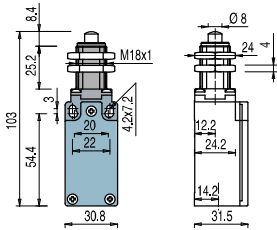
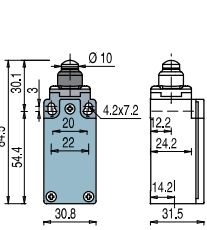

C5	R	LMC5A08	⊕	1NO+1NC	LMC5A12	⊕	1NO+1NC	LMC5A13	⊕	1NO+1NC	LMC5A14	⊕	1NO+1NC
C6	L	LMC6A08	⊕	1NO+1NC	LMC6A12	⊕	1NO+1NC	LMC6A13	⊕	1NO+1NC	LMC6A14	⊕	1NO+1NC
C7	LO	LMC7A08	⊕	1NO+1NC	LMC7A12	⊕	1NO+1NC	LMC7A13	⊕	1NO+1NC	LMC7A14	⊕	1NO+1NC
C9	L	LMC9A08	⊕	2NC	LMC9A12	⊕	2NC	LMC9A13	⊕	2NC	LMC9A14	⊕	2NC
C10	L	LMC10A08		2NO	LMC10A12		2NO	LMC10A13		2NO	LMC10A14		2NO
C11	R	LMC11A08	⊕	2NC	LMC11A12	⊕	2NC	LMC11A13	⊕	2NC	LMC11A14	⊕	2NC
C12	R	LMC12A08		2NO	LMC12A12		2NO	LMC12A13		2NO	LMC12A14		2NO
C13	LV	LMC13A08	⊕	2NC	LMC13A12	⊕	2NC	LMC13A13	⊕	2NC	LMC13A14	⊕	2NC
C14	LS	LMC14A08	⊕	2NC	LMC14A12	⊕	2NC	LMC14A13	⊕	2NC	LMC14A14	⊕	2NC
C15	LS	LMC15A08		2NO	LMC15A12		2NO	LMC15A13		2NO	LMC15A14		2NO
C18	LA	LMC18A08	⊕	1NO+1NC	LMC18A12	⊕	1NO+1NC	LMC18A13	⊕	1NO+1NC	LMC18A14	⊕	1NO+1NC
C20	L	LMC20A08	⊕	1NO+2NC	LMC20A12	⊕	1NO+2NC	LMC20A13	⊕	1NO+2NC	LMC20A14	⊕	1NO+2NC
C21	L	LMC21A08	⊕	3NC	LMC21A12	⊕	3NC	LMC21A13	⊕	3NC	LMC21A14	⊕	3NC
C22	L	LMC22A08	⊕	2NO+1NC	LMC22A12	⊕	2NO+1NC	LMC22A13	⊕	2NO+1NC	LMC22A14	⊕	2NO+1NC
C2	R	LMC2A08		2x(1NO-1NC)	LMC2A12		2x(1NO-1NC)	LMC2A13		2x(1NO-1NC)	LMC2A14		2x(1NO-1NC)
CE1	⏏	LMCE1A08		1NO-1NC	LMCE1A12		1NO-1NC	LMCE1A13		1NO-1NC	LMCE1A14		1NO-1NC
Max. speed		Type 4		Type 4		Type 2		Type 4					
Min. force		8 N (25 N ⊕)		8 N (25 N ⊕)		8 N (25 N ⊕)		8 N (25 N ⊕)					
Travel diagrams		Group 1		Group 1		Group 1		Group 1					

Roller, Ø 12 mm, stainless steel

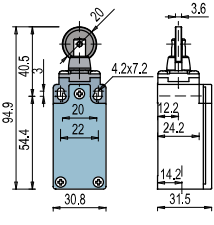
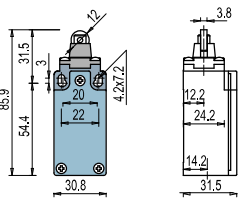

With external rubber gasket

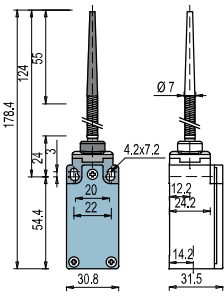

With external rubber gasket

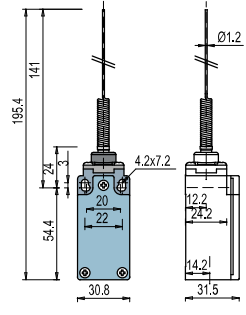

Contact blocks

C5	R	LMC5A15	⊕	1NO+1NC	LMC5A16	⊕	1NO+1NC	LMC5A20	1NO+1NC	LMC5A21	1NO+1NC		
C6	L	LMC6A15	⊕	1NO+1NC	LMC6A16	⊕	1NO+1NC						
C7	LO	LMC7A15	⊕	1NO+1NC	LMC7A16	⊕	1NO+1NC						
C9	L	LMC9A15	⊕	2NC	LMC9A16	⊕	2NC						
C10	L	LMC10A15		2NO	LMC10A16		2NO	LMC10A20	2NO	LMC10A21	2NO		
C11	R	LMC11A15	⊕	2NC	LMC11A16	⊕	2NC						
C12	R	LMC12A15		2NO	LMC12A16		2NO	LMC12A20	2NO	LMC12A21	2NO		
C13	LV	LMC13A15	⊕	2NC	LMC13A16	⊕	2NC						
C14	LS	LMC14A15	⊕	2NC	LMC14A16	⊕	2NC						
C15	LS	LMC15A15		2NO	LMC15A16		2NO						
C18	LA	LMC18A15	⊕	1NO+1NC	LMC18A16	⊕	1NO+1NC	LMC18A20	1NO+1NC	LMC18A21	1NO+1NC		
C20	L	LMC20A15	⊕	1NO+2NC	LMC20A16	⊕	1NO+2NC	LMC20A20	1NO+2NC	LMC20A21	1NO+2NC		
C21	L	LMC21A15	⊕	3NC	LMC21A16	⊕	3NC	LMC21A20	3NC	LMC21A21	3NC		
C22	L	LMC22A15	⊕	2NO+1NC	LMC22A16	⊕	2NO+1NC	LMC22A20	2NO+1NC	LMC22A21	2NO+1NC		
C2	R	LMC2A15		2x(1NO-1NC)	LMC2A16		2x(1NO-1NC)	LMC2A20	2x(1NO-1NC)	LMC2A21	2x(1NO-1NC)		
CE1	⏏	LMCE1A15		1NO-1NC	LMCE1A16		1NO-1NC	LMCE1A20	1NO-1NC	LMCE1A21	1NO-1NC		
Max. speed		Type 2		Type 2		1 m/s		1 m/s					
Min. force		8 N (25 N ⊕)		8 N (25 N ⊕)		0.07 Nm		0.07 Nm					
Travel diagrams		Group 1		Group 1		Group 4		Group 4					

All measures in the drawings are in mm

Contact type:

- R** = snap action
- L** = slow action
- LO** = slow action overlapped
- LS** = slow action shifted
- LV** = slow action shifted and spaced
- LI** = slow action independent
- LA** = slow action closer
- = electronic PNP

Contact blocks

	With external rubber gasket	With Ø 20 mm stainless steel roller on request	Square rod, 3x3 mm	
C5	R LMC5A25 1NO+1NC	R LMC5A30 1NO+1NC	LMC5A33 1NO+1NC	R LMC5A31 1NO+1NC
C6	L LMC6A25 1NO+1NC	R LMC6A30 1NO+1NC	LMC6A33 1NO+1NC	R LMC6A31 1NO+1NC
C7	LO LMC7A25 1NO+1NC	R LMC7A30 1NO+1NC	LMC7A33 1NO+1NC	R LMC7A31 1NO+1NC
C9	L LMC9A25 2NC	R LMC9A30 2NC	LMC9A33 2NC	R LMC9A31 2NC
C10	L LMC10A25 2NO	LMC10A30 2NO	LMC10A33 2NO	LMC10A31 2NO
C11	R LMC11A25 2NC	R LMC11A30 2NC	LMC11A33 2NC	R LMC11A31 2NC
C12	R LMC12A25 2NO	LMC12A30 2NO	LMC12A33 2NO	LMC12A31 2NO
C13	LV LMC13A25 2NC	R LMC13A30 2NC	LMC13A33 2NC	R LMC13A31 2NC
C14	LS LMC14A25 2NC	R LMC14A30 2NC	LMC14A33 2NC	R LMC14A31 2NC
C15	LS LMC15A25 2NO	LMC15A30 2NO	LMC15A33 2NO	LMC15A31 2NO
C16	LI LMC16A25 2NC	R LMC16A30 2NC	LMC16A33 2NC	R LMC16A31 2NC
C18	LA LMC18A25 1NO+1NC	R LMC18A30 1NO+1NC	LMC18A33 1NO+1NC	R LMC18A31 1NO+1NC
C20	L LMC20A25 1NO+2NC	R LMC20A30 1NO+2NC	LMC20A33 1NO+2NC	R LMC20A31 1NO+2NC
C21	L LMC21A25 3NC	R LMC21A30 3NC	LMC21A33 3NC	R LMC21A31 3NC
C22	L LMC22A25 2NO+1NC	R LMC22A30 2NO+1NC	LMC22A33 2NO+1NC	R LMC22A31 2NO+1NC
C2	R LMC2A25 2x(1NO-1NC)	LMC2A30 2x(1NO-1NC)	LMC2A33 2x(1NO-1NC)	LMC2A31 2x(1NO-1NC)
CE1	LMCE1A25 1NO-1NC	LMCE1A30 1NO-1NC	LMCE1A33 1NO-1NC	LMCE1A31 1NO-1NC
Max. speed	1 m/s	Type 1	1.5 m/s	Type 1
Min. force	0.12 Nm	0.06 Nm (0.25 Nm \ominus)	0.06 Nm	0.06 Nm (0.25 Nm \ominus)
Travel diagrams	Group 4	Group 5	Group 5	Group 5

	With external rubber gasket	Round rod, Ø 3 mm, stainless steel	Square rod, 3x3 mm	
C5	R LMC5A34 1NO+1NC	R LMC5A50 1NO+1NC	R LMC5A51 1NO+1NC	R LMC5A52 1NO+1NC
C6	L LMC6A34 1NO+1NC	R LMC6A50 1NO+1NC	R LMC6A51 1NO+1NC	R LMC6A52 1NO+1NC
C7	LO LMC7A34 1NO+1NC	R LMC7A50 1NO+1NC	R LMC7A51 1NO+1NC	R LMC7A52 1NO+1NC
C9	L LMC9A34 2NC	R LMC9A50 2NC	R LMC9A51 2NC	R LMC9A52 2NC
C10	L LMC10A34 2NO	LMC10A50 2NO	LMC10A51 2NO	LMC10A52 2NO
C11	R LMC11A34 2NC	R LMC11A50 2NC	R LMC11A51 2NC	R LMC11A52 2NC
C12	R LMC12A34 2NO	LMC12A50 2NO	LMC12A51 2NO	LMC12A52 2NO
C13	LV LMC13A34 2NC	R LMC13A50 2NC	R LMC13A51 2NC	R LMC13A52 2NC
C14	LS LMC14A34 2NC	R LMC14A50 2NC	R LMC14A51 2NC	R LMC14A52 2NC
C15	LS LMC15A34 2NO	LMC15A50 2NO	LMC15A51 2NO	LMC15A52 2NO
C16	LI LMC16A34 2NC	R LMC16A50 2NC	R LMC16A51 2NC	R LMC16A52 2NC
C18	LA LMC18A34 1NO+1NC	R LMC18A50 1NO+1NC	R LMC18A51 1NO+1NC	R LMC18A52 1NO+1NC
C20	L LMC20A34 1NO+2NC	R LMC20A50 1NO+2NC	R LMC20A51 1NO+2NC	R LMC20A52 1NO+2NC
C21	L LMC21A34 3NC	R LMC21A50 3NC	R LMC21A51 3NC	R LMC21A52 3NC
C22	L LMC22A34 2NO+1NC	R LMC22A50 2NO+1NC	R LMC22A51 2NO+1NC	R LMC22A52 2NO+1NC
C2	R LMC2A34 2x(1NO-1NC)	LMC2A50 2x(1NO-1NC)	LMC2A51 2x(1NO-1NC)	LMC2A52 2x(1NO-1NC)
CE1	LMCE1A34 1NO-1NC	LMCE1A50 1NO-1NC	LMCE1A51 1NO-1NC	LMCE1A52 1NO-1NC
Max. speed	1.5 m/s	1.5 m/s	Type 1	Type 1
Min. force	0.06 Nm	0.06 Nm	0.06 Nm (0.25 Nm \ominus)	0.06 Nm (0.25 Nm \ominus)
Travel diagrams	Group 5	Group 5	Group 5	Group 5

All measures in the drawings are in mm

Contact type:

- R** = snap action
- L** = slow action
- LO** = slow action overlapped
- LS** = slow action shifted
- LV** = slow action shifted and spaced
- LI** = slow action independent
- LA** = slow action closer
- = electronic PNP

Porcelain roller

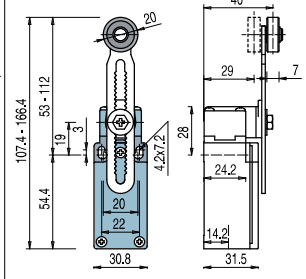
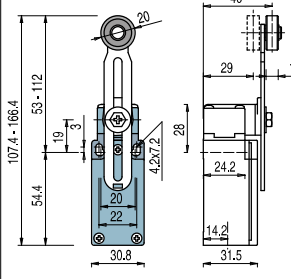
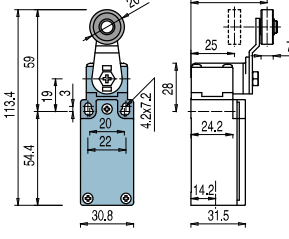
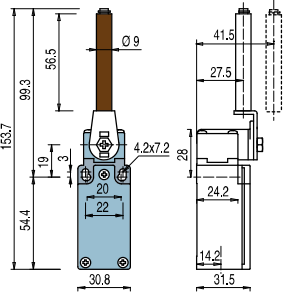

Contact blocks

C5	R	LMC5A53	⊕ 1NO+1NC	LMC5A54	⊕ 1NO+1NC	LMC5A55	⊕ (1) 1NO+1NC	LMC5A56	⊕ 1NO+1NC
C6	L	LMC6A53	⊕ 1NO+1NC	LMC6A54	⊕ 1NO+1NC	LMC6A55	⊕ (1) 1NO+1NC	LMC6A56	⊕ 1NO+1NC
C7	LO	LMC7A53	⊕ 1NO+1NC	LMC7A54	⊕ 1NO+1NC	LMC7A55	⊕ (1) 1NO+1NC	LMC7A56	⊕ 1NO+1NC
C9	L	LMC9A53	⊕ 2NC	LMC9A54	⊕ 2NC	LMC9A55	⊕ (1) 2NC	LMC9A56	⊕ 2NC
C10	L	LMC10A53	2NO	LMC10A54	2NO	LMC10A55	2NO	LMC10A56	2NO
C11	R	LMC11A53	⊕ 2NC	LMC11A54	⊕ 2NC	LMC11A55	⊕ (1) 2NC	LMC11A56	⊕ 2NC
C12	R	LMC12A53	2NO	LMC12A54	2NO	LMC12A55	2NO	LMC12A56	2NO
C13	LV	LMC13A53	⊕ 2NC	LMC13A54	⊕ 2NC	LMC13A55	⊕ (1) 2NC	LMC13A56	⊕ 2NC
C14	LS	LMC14A53	⊕ 2NC	LMC14A54	⊕ 2NC	LMC14A55	⊕ (1) 2NC	LMC14A56	⊕ 2NC
C15	LS	LMC15A53	2NO	LMC15A54	2NO	LMC15A55	2NO	LMC15A56	2NO
C16	LI	LMC16A53	⊕ 2NC	LMC16A54	⊕ 2NC	LMC16A55	⊕ (1) 2NC	LMC16A56	⊕ 2NC
C18	LA	LMC18A53	⊕ 1NO+1NC	LMC18A54	⊕ 1NO+1NC	LMC18A55	⊕ (1) 1NO+1NC	LMC18A56	⊕ 1NO+1NC
C20	L	LMC20A53	⊕ 1NO+2NC	LMC20A54	⊕ 1NO+2NC	LMC20A55	⊕ (1) 1NO+2NC	LMC20A56	⊕ 1NO+2NC
C21	L	LMC21A53	⊕ 3NC	LMC21A54	⊕ 3NC	LMC21A55	⊕ (1) 3NC	LMC21A56	⊕ 3NC
C22	L	LMC22A53	⊕ 2NO+1NC	LMC22A54	⊕ 2NO+1NC	LMC22A55	⊕ (1) 2NO+1NC	LMC22A56	⊕ 2NO+1NC
C2	R	LMC2A53	2x(1NO-1NC)	LMC2A54	2x(1NO-1NC)	LMC2A55	2x(1NO-1NC)	LMC2A56	2x(1NO-1NC)
CE1		LMCE1A53	1NO-1NC	LMCE1A54	1NO-1NC	LMCE1A55	1NO-1NC	LMCE1A56	1NO-1NC
Max. speed		0.5 m/s		Type 1		Type 1		Type 1	
Min. force		0.03 Nm (0.25 Nm ⊕)		0.06 Nm (0.25 Nm ⊖)		0.06 Nm (0.25 Nm ⊕)		0.06 Nm (0.25 Nm ⊕)	
Travel diagrams		Group 6		Group 5		Group 5		Group 5	

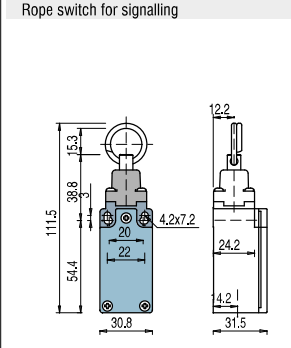
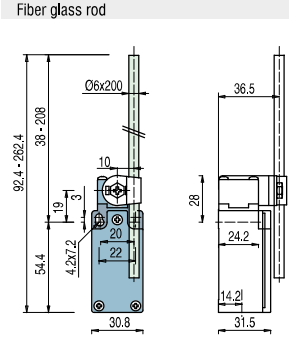
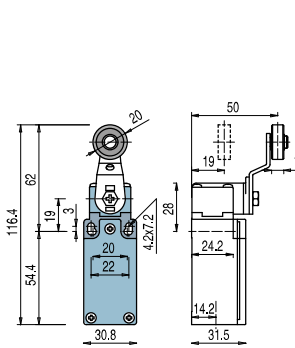

Contact blocks

C5	R	LMC5A57	⊕ 1NO+1NC	LMC5A69	1NO+1NC	LMC5A76	1NO+1NC		
C6	L	LMC6A57	⊕ 1NO+1NC	LMC6A69	1NO+1NC	LMC6A76	1NO+1NC		
C7	LO	LMC7A57	⊕ 1NO+1NC	LMC7A69	1NO+1NC	LMC7A76	1NO+1NC		
C9	L	LMC9A57	⊕ 2NC	LMC9A69	2NC	LMC9A76	2NO		
C10	L	LMC10A57	2NO	LMC10A69	2NO	LMC10A76	2NC		
C11	R	LMC11A57	⊕ 2NC	LMC11A69	2NC	LMC11A76	2NO		
C12	R	LMC12A57	2NO	LMC12A69	2NO	LMC12A76	2NC		
C13	LV	LMC13A57	⊕ 2NC	LMC13A69	2NC	LMC13A76	2NO		
C14	LS	LMC14A57	⊕ 2NC	LMC14A69	2NC	LMC14A76	2NO		
C15	LS	LMC15A57	2NO	LMC15A69	2NO	LMC15A76	2NC		
C16	LI	LMC16A57	⊕ 2NC	LMC16A69	2NC				
C18	LA	LMC18A57	⊕ 1NO+1NC	LMC18A69	1NO+1NC	LMC18A76	1NO+1NC		
C20	L	LMC20A57	⊕ 1NO+2NC	LMC20A69	1NO+2NC	LMC20A76	2NO+1NC		
C21	L	LMC21A57	⊕ 3NC	LMC21A69	3NC	LMC21A76	3NO		
C22	L	LMC22A57	⊕ 2NO+1NC	LMC22A69	2NO+1NC	LMC22A76	1NO+2NC		
C2	R	LMC2A57	2x(1NO-1NC)	LMC2A69	2x(1NO-1NC)	LMC2A76	2x(1NO-1NC)		
CE1		LMCE1A57	1NO-1NC	LMCE1A69	1NO-1NC				
Max. speed		Type 1		1.5 m/s		0.5 m/s			
Min. force		0.06 Nm (0.25 Nm ⊕)		0.06 Nm		initial 20 N - final 40 N			
Travel diagrams		Group 5		Group 5		Group 7			

(1) Positive opening only with actuator set to max

All measures in the drawings are in mm



IMO Precision Controls has developed a range of position switches that incorporate a Reset device. This is denoted by the addition of the suffix R to the part numbers. The Reset device is a block inserted between the switch body and the head, and it can be rotated and positioned in four locations independent to the head. Some of the features of the Reset device are as follows:

- Easy integration in to almost all standard heads
- No need to use snap action contact blocks as the tripping movement is defined by the Reset device
- Rotation for ease of installation
- Two driving forces are available - standard and increased for use in applications where vibration is present
- Mechanical endurance - up to 1 million operating cycles.

Contact type:

- R** = snap action
- L** = slow action

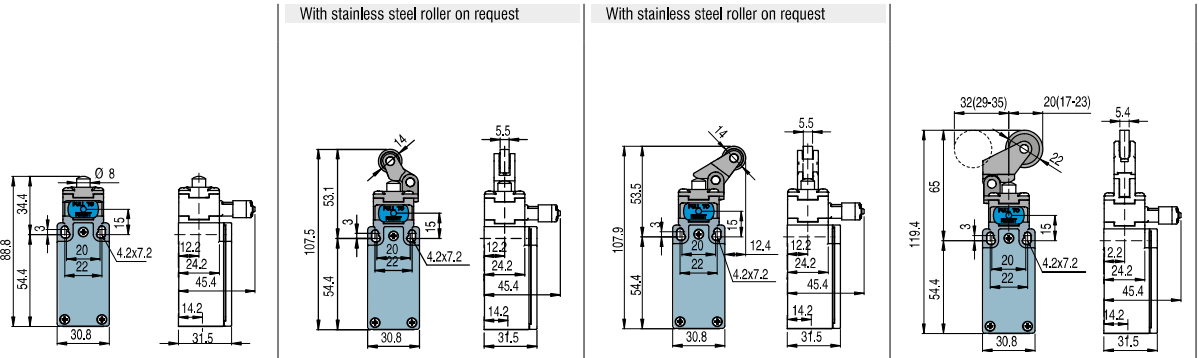

Contact blocks

C6	L	LMC6A01-R20	⊕ 1NO+1NC	LMC6A02-R20	⊕ 1NO+1NC	LMC6A05-R20	⊕ 1NO+1NC	LMC6A07-R20	⊕ 1NO+1NC
C9	L	LMC9A01-R20	⊕ 2NC	LMC9A02-R20	⊕ 2NC	LMC9A05-R20	⊕ 2NC	LMC9A07-R20	⊕ 2NC
C10	L	LMC10A01-R20	2NO	LMC10A02-R20	2NO	LMC10A05-R20	2NO	LMC10A07-R20	2NO
C20	L	LMC20A01-R20	⊕ 1NO+2NC	LMC20A02-R20	⊕ 1NO+2NC	LMC20A05-R20	⊕ 1NO+2NC	LMC20A07-R20	⊕ 1NO+2NC
C21	L	LMC21A01-R20	⊕ 3NC	LMC21A02-R20	⊕ 3NC	LMC21A05-R20	⊕ 3NC	LMC21A07-R20	⊕ 3NC
C22	L	LMC22A01-R20	⊕ 2NO+1NC	LMC22A02-R20	⊕ 2NO+1NC	LMC22A05-R20	⊕ 2NO+1NC	LMC22A07-R20	⊕ 2NO+1NC
C2	R	LMC2A01-R20	2NO+2NC	LMC2A02-R20	2NO+2NC	LMC2A05-R20	2NO+2NC	LMC2A07-R20	2NO+2NC
Max. speed		Type 4		Type 3		Type 3		Type 3	
Min. force		4.5 N (25 N ⊕)		4 N (25 N ⊕)		4 N (25 N ⊕)		2.5 N (25 N ⊕)	
Travel diagrams		Group 1		Group 2		Group 2		Group 3	

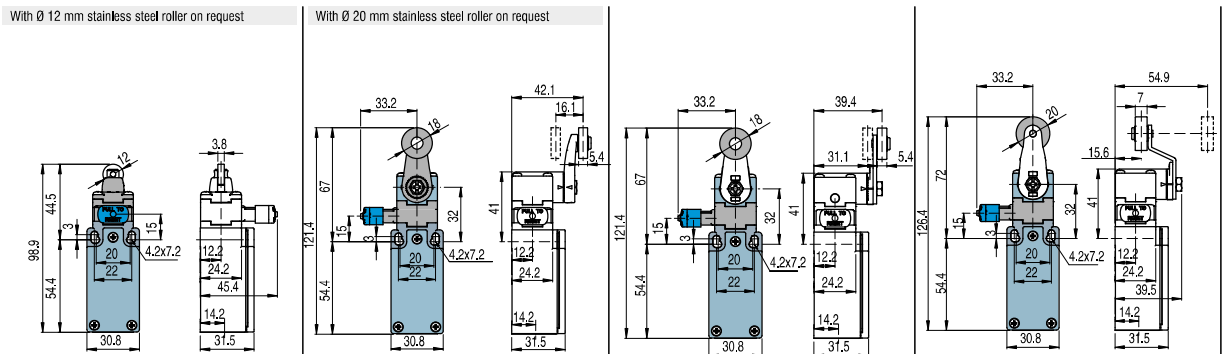

Contact blocks

C6	L	LMC6A15-R20	⊕ 1NO+1NC	LMC6A30-R20	⊕ 1NO+1NC	LMC6A31-R20	⊕ 1NO+1NC	LMC6A51-R20	⊕ 1NO+1NC
C9	L	LMC9A15-R20	⊕ 2NC	LMC9A30-R20	⊕ 2NC	LMC9A31-R20	⊕ 2NC	LMC9A51-R20	⊕ 2NC
C10	L	LMC10A15-R20	2NO	LMC10A30-R20	2NO	LMC10A31-R20	2NO	LMC10A51-R20	2NO
C20	L	LMC20A15-R20	⊕ 1NO+2NC	LMC20A30-R20	⊕ 1NO+2NC	LMC20A31-R20	⊕ 1NO+2NC	LMC20A51-R20	⊕ 1NO+2NC
C21	L	LMC21A15-R20	⊕ 3NC	LMC21A30-R20	⊕ 3NC	LMC21A31-R20	⊕ 3NC	LMC21A51-R20	⊕ 3NC
C22	L	LMC22A15-R20	⊕ 2NO+1NC	LMC22A30-R20	⊕ 2NO+1NC	LMC22A31-R20	⊕ 2NO+1NC	LMC22A51-R20	⊕ 2NO+1NC
C2	R	LMC2A15-R20	2NO+2NC	LMC2A30-R20	2NO+2NC	LMC2A31-R20	2NO+2NC	LMC2A51-R20	2NO+2NC
Max. speed		Type 2		Type 1		Type 1		Type 1	
Min. force		4.5 N (25 N ⊕)		0.07 Nm (0.25 Nm ⊕)		0.07 Nm (0.25 Nm ⊕)		0.07 Nm (0.25 Nm ⊕)	
Travel diagrams		Group 1		Group 4		Group 4		Group 4	

All measures in the drawings are in mm

Contact type:

- R** = snap action
- L** = slow action

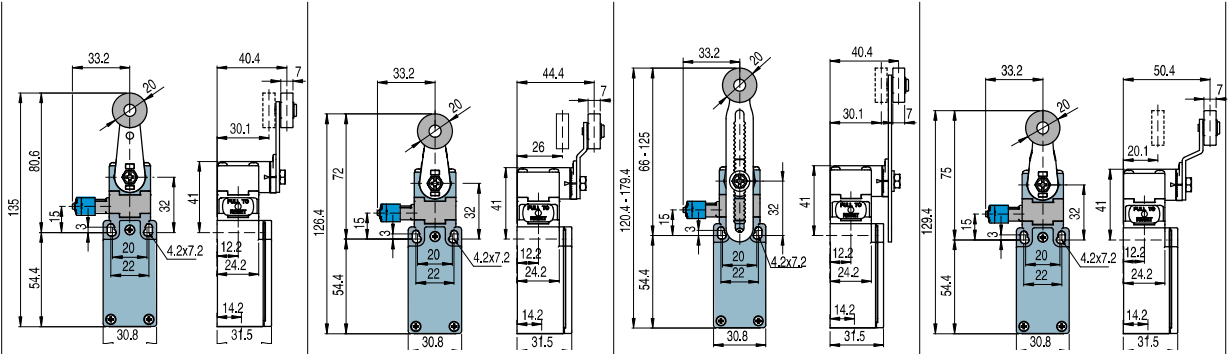

Contact blocks

C6	L	LMC6A52-R20	⊕ 1NO+1NC	LMC6A54-R20	⊕ 1NO+1NC	LMC6A56-R20	⊕ 1NO+1NC	LMC6A57-R20	⊕ 1NO+1NC
C9	L	LMC9A52-R20	⊕ 2NC	LMC9A54-R20	⊕ 2NC	LMC9A56-R20	⊕ 2NC	LMC9A57-R20	⊕ 2NC
C10	L	LMC10A52-R20	2NO	LMC10A54-R20	2NO	LMC10A56-R20	2NO	LMC10A57-R20	2NO
C20	L	LMC20A52-R20	⊕ 1NO+2NC	LMC20A54-R20	⊕ 1NO+2NC	LMC20A56-R20	⊕ 1NO+2NC	LMC20A57-R20	⊕ 1NO+2NC
C21	L	LMC21A52-R20	⊕ 3NC	LMC21A54-R20	⊕ 3NC	LMC21A56-R20	⊕ 3NC	LMC21A57-R20	⊕ 3NC
C22	L	LMC22A52-R20	⊕ 2NO+1NC	LMC22A54-R20	⊕ 2NO+1NC	LMC22A56-R20	⊕ 2NO+1NC	LMC22A57-R20	⊕ 2NO+1NC
C2	R	LMC2A52-R20	2NO+2NC	LMC2A54-R20	2NO+2NC	LMC2A56-R20	2NO+2NC	LMC2A57-R20	2NO+2NC
Max. speed		Type 1		Type 1		Type 1		Type 1	
Min. force		0.07 Nm (0.25 Nm ⊕)		0.07 Nm (0.25 Nm ⊕)		0.07 Nm (0.25 Nm ⊕)		0.07 Nm (0.25 Nm ⊕)	
Travel diagrams		Group 4		Group 4		Group 4		Group 4	

All measures in the drawings are in mm

Increased actuating force

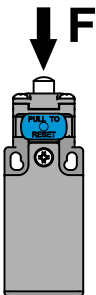

The switch can be delivered with increased actuating force. Ideal for applications with vibrations.

Actuators	Min. force
01, 14, 15, 16	7 N
02, 05	6 N
07	3.5 N
30 ... 57	0.08 Nm

Position switches with revolving lever without actuator

Contact type:

- R** = snap action
- L** = slow action
- LO** = slow action overlapped
- LS** = slow action shifted
- LV** = slow action shifted and spaced
- LI** = slow action independent
- LA** = slow action closer
- ⚡** = electronic PNP

Contact blocks

Contact type	Product Code	Configuration	Product Code	Configuration
C5	R			
C6	L	LMC6A38-20	LMC6A38-R20	1NO+1NC
C7	LO			
C9	L	LMC9A38-20	LMC9A38-R20	2NC
C10	L			
C11	R	LMC11A38-20		2NC
C12	R			
C13	LV	LMC13A38-20		2NC
C14	LS			
C15	LS	LMC15A38-20		2NO
C16	LI			
C18	LA	LMC18A38-20		1NO+1NC
C20	L			
C21	L	LMC21A38-20	LMC21A38-R20	3NC
C22	L			
C2	R	LMC2A38-20	LMC2A38-R20	2x(1NO-1NC) / 2NO+2NC
CE1	⚡			
Min. force		0.06 Nm (0.25 Nm)		0.07 Nm (0.25 Nm)
Travel diagrams		Group 5		Group 4

All measures in the drawings are in mm

All measures in the drawings are in mm

IMPORTANT

For safety applications: join only switches and actuators marked with symbol aside the product code.

Loose actuators

All measures in the drawings are in mm

IMPORTANT: These loose actuators can be used with items of series LR, LM, LX, LZ and LK only.

Technopolymer roller Ø 18 mm	Technopolymer roller Ø 18 mm	Adjustable square rod, 3x3x125 mm	Flexible rod with pointed end	Adjustable round rod Ø 3x125 mm	Technopolymer roller Ø 20 mm	
AC-CAE30	AC-CAE31	AC-CAE33	AC-CAE34	AC-CAE50	AC-CAE51	
Technopolymer roller Ø 20 mm	Porcelain roller	Technopolymer roller Ø 20 mm	Adjustable actuator with technopolymer roller	Adjustable safety actuator with technopolymer roller	Technopolymer roller Ø 20 mm	Adjustable fiber glass rod
AC-CAE52	AC-CAE53 ⁽²⁾	CA-CAE54	AC-CAE55 ⁽¹⁾	AC-CAE56	AC-CAE57	AC-CAE69

- (1) Actuator AC-CAE55 can only be used in safety applications if adjusted to its max. length, as shown in figure beside. If you need an adjustable lever for safety applications, use the adjustable safety lever AC-CAE56.
- (2) The position switch obtained by assembling switch LM • A38-20 (e.g. LMC5A38-20, LMC6A38-20...) with actuator AC-CAE53 will not present the same travel diagrams and actuating forces as switch LM • A53-JOST (e.g. LMC5A53-JOST, LMC6A53-JOST...).
- (4) The actuator cannot be rotated to the inside because it will mechanically interfere with the switch head.

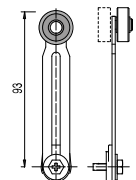

Special loose actuators

All measures in the drawings are in mm

IMPORTANT: These loose actuators can be used with items of series LR, LM, LX, LZ and LK only.

Stainless steel rollers, Ø 20 mm

AC-CAE31-R24 (1)	AC-CAE51-R24 (1)	AC-CAE52-R24 (1)	AC-CAE54-R24 (1)	AC-CAE55-R24 (1) (1)	AC-CAE56-R24 (1)	AC-CAE57-R24 (1)

Technopolymer rollers, Ø 35 mm

AC-CAE31-R25 (4)	AC-CAE51-R25 (4)	AC-CAE52-R25 (4)	AC-CAE54-R25 (4)	AC-CAE55-R25 (1)	AC-CAE56-R25 (1)	AC-CAE57-R25 (1)

Rubber rollers, Ø 40 mm

AC-CAE31-R5 (4)	AC-CAE51-R5 (4)	AC-CAE52-R5 (4)	AC-CAE54-R5 (4)	AC-CAE55-R5 (1)	AC-CAE56-R5 (1)	AC-CAE57-R5 (4)

Rubber rollers, Ø 50 mm

AC-CAE51-R26 (4)	AC-CAE2-R26 (4)	AC-CAE54-R26 (4)	AC-CAE55-R26 (1)	AC-CAE56-R26 (1)	AC-CAE57-R26 (4)

Protruding rubber rollers, Ø 50 mm

AC-CAE55-R27 (1)	AC-CAE56-R27 (1)

Maximum and minimum actuation speed

Lever with roller - Type 1

Ø	Vmax (m/s)	Vmin (mm/s)	
		L	R
15°	2.5	9	0.07
30°	1.5	8	
45°	1	7	
60°	0.75	7	

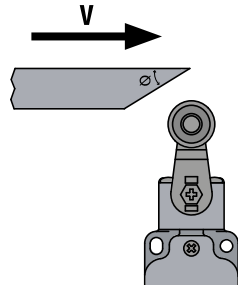

Plunger with roller - Type 2

Ø	Vmax (m/s)	Vmin (mm/s)	
		L	R
15°	1	4	0.04
30°	0.5	2	0.02
45°	0.3	1	0.01

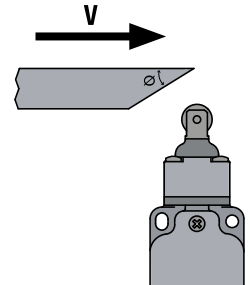

Lever with roller - Type 3

Ø	Vmax (m/s)	Vmin (mm/s)	
		L	R
15°	1	5	0.05
30°	0.5	2.5	0.025
45°	0.3	1.5	0.015

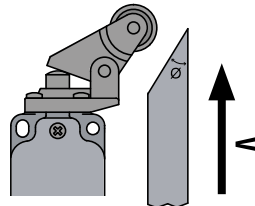

Plunger with roller - Type 5

Ø	Vmax (m/s)	Vmin (mm/s)	
		L	R
15°	0.3	4	0.04
30°	0.2	2	0.02

Plunger with roller - Type 4

Vmax (m/s)	Vmin (mm/s)	
	L	R
0.5	1	0.01

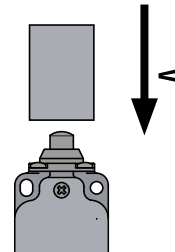

Contacts Type:

- R = snap action
- L = slow action

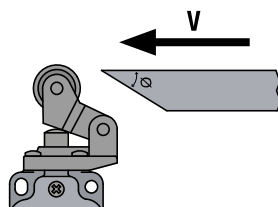

Driving Torques For LM and LZ series only

- | | | |
|---|--|---|
| 1 | Cover screws | 0.8...1.2Nm |
| 2 | Head screws | 0.8...1.2Nm |
| 3 | Lever screws | 0.8...1.2Nm |
| 4 | Protection plugs | 1.2...1.6Nm
(conduit entry M20/PG13.5)
(conduit entry M16/PG11) |
| 5 | Contact block screws | 1.0...1.4Nm |
| 6 | M5 screws of the housing fastening with washer | 0.6...0.8Nm
2.0...3.0Nm |

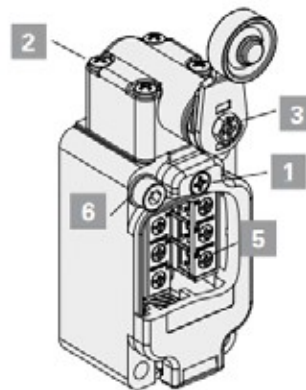

Travel Diagrams

Contact block		Group 1	Group 2	Group 3	Group 4
6 1NO+1NC					
9 2NC					
10 2NO					
20 1NO+2NC					
21 3NC					
22 2NO+1NC					
33 1NO+1NC					
34 2NC					
2 2x(1NO-1NC)					

Legend
 Closed contact | Opened contact | Positive opening travel | Pushing the switch / Releasing the switch

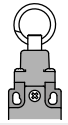
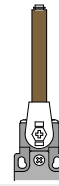
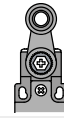
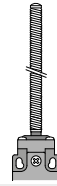

Contact block		Group 1	Group 2	Group 3	Group 4	Group 5	Group 6	Group 7 inverted contacts
2 2x(1NO-1NC)								
3 1NO-1NC								
5 1NO+1NC								
6 1NO+1NC					/			
7 1NO+1NC					/			
9 2NC					/			
10 2NO								
11 2NC					/		/	
12 2NO								
13 2NC					/			
14 2NC					/			
15 2NO					/			
16 2NC		/	/	/	/		/	/
18 1NO+1NC								
20 1NO+2NC								
21 3NC								
22 2NO+1NC								
28 1NO+2NC					/			
29 3NC					/			
30 3NC					/			
33 1NO+1NC								
34 2NC								
37 1NO+1NC					/			
66 1NC								
67 1NO								

Legend

Closed contact |
 Opened contact |
 Positive opening travel |
 Pushing the switch /
 Releasing the switch